

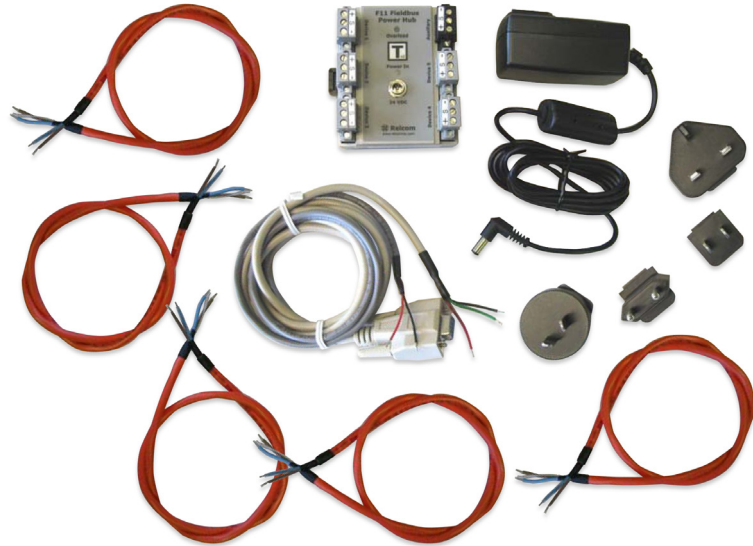

F11 - YK2

power conditioner and cables for temporary fieldbus network

- built-in fieldbus power conditioning
- 5 fieldbus device ports
- 30mA current per device
- up to 315mA total current
- auxiliary port for expansion
- fieldbus device cables and interface card cable
- complete with AC power supply
- battery-pack option



The Relcom Fieldbus Labkit (F11-YK2) is a convenient kit containing the Relcom Fieldbus Power Hub (F11) and six cables. Ideal for bench-tops, labs, demonstrations, and test setups, the Power Hub is a mini fieldbus segment in a box - just add devices and a host. The supplied cables allow connection to five fieldbus devices and a National Instruments Fieldbus Interface card (USB, PCMCIA, or PCI).

A plug-in wall transformer with an input voltage range of 100-240VAC (50-60Hz) is included with the Power Hub. Adapters are supplied with the transformer for four different country power outlets (North America, Europe, UK, and Australia).

Internally the Power Hub contains a fieldbus power conditioner, two built-in terminators, and SpurGuard™ current

limiters. There are five ports for attaching devices (gray connectors), and an Auxiliary Port (black connector) for connection of additional devices. Pluggable screw terminal connectors are used on all ports for the fieldbus connections. The connectors may be secured to the Power Hub with the two retaining screws if desired.

A minimum of 30mA is available for each device port. If the current requirements of a Fieldbus device exceed the capability of the Device port, the Auxiliary Port can be used to provide additional power conditioned current. A total of 315mA can be supplied by the Power Hub. If any of the Device Ports or the Auxiliary Port is overloaded, a red Overload indicator will light.

For applications where AC power may not be available, the FCS-A11 Battery Pack may

be used to supply power to the Power Hub. For more information on the FCS-A11 Battery Pack, see our datasheet EPS FCS-A11.

For convenience, the Power Hub can be mounted on standard 'top hat' 35mm DIN rail.

A typical use for the Power Hub is to configure, precommission, test, or calibrate fieldbus devices. In this case, the fieldbus device and host device (fieldbus DCS, Emerson 375 or 475, National Instruments Fieldbus Interface, etc.) are connected to the Power Hub. No other components are required to have a functioning fieldbus segment.

Note: The F11 Power Hub is not intended to be used in a permanent installation.

SPECIFICATIONS

ELECTRICAL

Device Port Rated Current
30mA

Total Current for all Device Ports and Auxiliary Port
315mA max. (for specified operation)

Device Port Short Circuit Protection
Continuous protection against damage

Maximum Fieldbus Cable Length
120 metres

Auxiliary Port Short Circuit Protection
Continuous protection against damage

Wall-mounted Bulk Power Supply
Input voltage: 100 - 240V AC, 50/60Hz
Output voltage: 24V DC (nominal)

Fieldbus Device Cable
1m - shielded twisted pair (x5)

National Instruments Cable
1m - DB9 to prepared wires

MECHANICAL

Fieldbus Connectors
Six sets, pluggable screw-terminal, with two securing screws

Mounting requirements
35mm DIN rail

Wire capacity
0.14 to 2.5mm²

Case material
Lexan polycarbonate

Temperature range
0° to +50°C

Weight
146g (nominal)

PHYSICAL NETWORK

IEC 61158-2
Foundation™ fieldbus H1
Profibus PA

ORDERING INFORMATION

F11 - YK2 Relcom Fieldbus Labkit

Battery Pack (Power Hub power in the field)

Heavy-duty DIN rail end stop

35mm DIN rail, aluminium, 1 meter

F11-YK2

FCS-A11

FCS-A06

FCS-A01

Wall Power Supply and Interchangeable Power Outlet Adapters (included with F11)



CASE DIMENSIONS

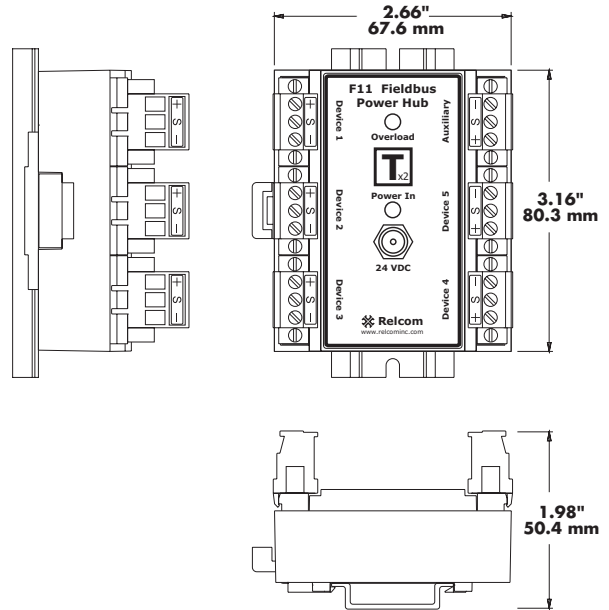

Connection diagram

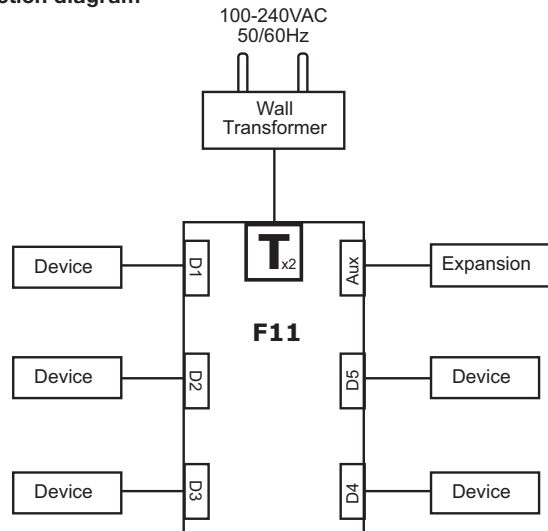

F11 together with optional FCS-A11 Battery Pack

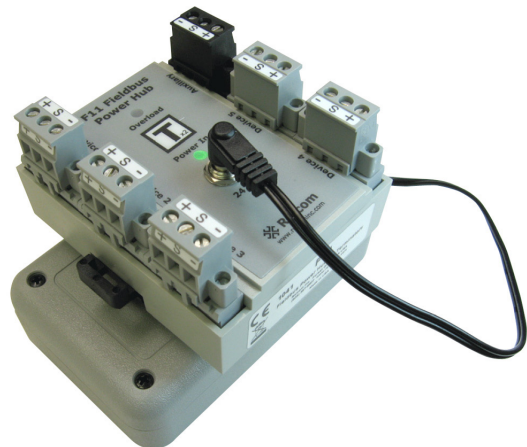

The given data is only intended as a product description and should not be regarded as a legal warranty of properties or guarantee. In the interest of further technical developments, we reserve the right to make design changes.



EUROPE (EMEA): +44 (0)1582 723633
enquiry@mtl-inst.com

THE AMERICAS: +1 800 835 7075
csinfo@mtl-inst.com

ASIA-PACIFIC: +65 6 487 7887
sales@mtlsing.com.sg

EPS F11-YK2 Rev1 050511