



9387-FB, 9388-FB

Fieldbus Barrier internal components, without enclosures

- For FOUNDATION™ fieldbus networks in hazardous areas
- Pre-assembled system components for 6 or 12 intrinsically safe spur connections
- For assembly into user-specified field enclosures
- Spurs compatible with FISCO and "Entity-certified" fieldbus instruments
- Ergonomic mechanical design
- Pluggable system components without "gas free" constraints
- Optional, integrated surge protection for trunk and spurs



The **9387-FB (6-spur)** and **9388-FB (12-spur) Fieldbus Barrier assemblies** provide intrinsically safe spur connections from a high-energy trunk, for connection to suitably certified Foundation™ fieldbus H1 instruments. Each unit comprises pre-wired and assembled system components on a stainless steel baseplate, for installation into a suitably certified field enclosure. Connection facilities are provided for the trunk and spur wiring, as well as all electronic modules needed to support a fully-working Fieldbus Barrier. In a typical application, an Ex e (increased safety) certified field enclosure will be selected to allow installation in a Zone 1 hazardous area; third-party approval of the enclosure and contents is normally required.

Alternative uses include applications that are not satisfied by the 9370-FB Series Fieldbus Barriers in standard enclosures, such as the installation of multiple fieldbus segments inside a single field enclosure.

Each intrinsically safe spur is capable of supporting a FISCO or 'Entity' certified fieldbus device located in a Zone 0 or 1 hazardous area. The short-circuit protected spurs are galvanically isolated from the trunk and require no protective ground connection in the field. The units are bus powered and require no additional power supply in the field. When used with a fieldbus host control system, power for the trunk may be provided by MTL power supplies in redundant or non-redundant format.

The 9387-FB and 9388-FB share the unique features of MTL's class-leading 9370-FB Series Fieldbus Barrier system. The key modular components of the system (Fieldbus Barrier, Terminator and Surge Protectors) may be 'hot-plugged' by design and without gas-clearance procedures or separate isolating switches. This virtually eliminates the risk associated with hazardous area maintenance activities, speeds module replacement and avoids the need for specialist operator training. Optional features include pluggable surge protection components for the fieldbus trunk and individual spurs.

SPECIFICATION

SPURS

	9387-FB	9388-FB
# of spurs	6	12
# of 9377-FB modules installed	1	2
Current per spur	0 - 40mA	0 - 40mA
Total current all spurs (max.)	240mA	480mA
Shorted spur current (max.)	45mA	
Spur voltage	≥ 10V @ 40mA	
No-load voltage	12V min.	

Number of field devices

1 per spur

Maximum spur length

120m (depending on the number of spurs per fieldbus segment)

Galvanic isolation (to EN 60079-11)

Trunk to spurs: 1.5kV (test voltage)

Spur to spur: no isolation

Spur surge protection

Plug-in module (part number FS32) - see separate specification

* See ordering information

TRUNK

Data rate

31.25kbaud

Data transmission between trunk and spurs

passive, no repeater function

Number of trunk connections

2 (in & out), internally connected

Input voltage (trunk)

16-32V DC

Low voltage monitoring

Input voltage < 16V, spurs de-energized

Typical DC current for 6 spur (9387-FB) and 12 spur (9388-FB)

units (mA)

	@ 16V		@ 24V		@ 32V	
	9387	9388	9387	9388	9387	9388
No load - 0mA each spur	68	136	49	98	41	82
20mA each spur	200	400	137	274	108	216
5 spurs @ 20mA, 1 in s/c	185	-	128	-	101	-
11 spurs @ 20mA, 1 in s/c	-	385	-	265	-	209
40mA each spur	332	664	220	440	168	336

	9387-FB	9388-FB
Power dissipation (max.)	2.85W	5.65W

Fieldbus terminator

Plug-in module (part number 9378-FT) supplied with each 9387-FB or 9388-FB assembly.

Provides 100Ω + 1μF according to IEC 61158-2 - see separate specification

Trunk surge protection

Plug-in module (part number 9376-SP) - see separate specification

Reverse polarity protection

Yes

ELECTRICAL CONNECTIONS

Trunk wiring terminals

Type: Ex e

Cable types and capacity	Screw cage clamp - mm ²	Spring cage clamp - mm ²
Rigid cable	0.5 to 4.0	0.5 to 4.0
Flexible cable	0.5 to 2.5	0.5 to 2.5

Spur field wiring terminals

Type: 3-way, pluggable

Cable types and capacity	Screw cage clamp - mm ²	Spring cage clamp - mm ²
Rigid cable	0.2 to 2.5	0.2 to 2.5
Flexible cable	0.25 to 2.5	0.25 to 2.5

Grounding of cable screens (trunk & spurs)

(Configured with wire connections in the Trunk Terminal Assembly)

Options	Trunk	Spurs
1 Single point grounding	Grounded at host	Trunk & spur screens joined
2 Local grounding of spurs	Grounded at host	Grounded at field enclosure

Equipotential earth/ground connection facility

M10 earth/grounding stud on baseplate

BARRIER LED INDICATORS

Trunk Power (PWR)

	ON	OFF
Green	Supply voltage > 16V, internal supply healthy	Supply voltage < 16V or no supply

Spurs (tri-colour, per spur)

Colour	Steady	Flashing
Green	Channel powering spur - spur OK	Channel powering spur - spur open
Red	Internal fault	Internal fault
Yellow	Short to shield	Short circuit, current limit
Off	Supply < 16V or no supply	N.A.

PHYSICAL NETWORKS

IEC61158-2
FOUNDATION™ fieldbus H1

The given data is only intended as a product description and should not be regarded as a legal warranty of properties or guarantee. In the interest of further technical developments, we reserve the right to make design changes.



EUROPE (EMEA): +44 (0)1582 723633
enquiry@mtl-inst.com

THE AMERICAS: +1 800 835 7075
csinfo@mtl-inst.com

ASIA-PACIFIC: +65 6 487 7887
sales@mtlsing.com.sg

EPS 9370-FB-1 021111

HAZARDOUS AREA APPROVALS

Location of equipment

Zone 1 IIC T4 hazardous area when mounted inside a suitably certified Ex e enclosure

Location of connected spur equipment

Zone 0 IIC hazardous area

Certification codes

Ex II 2(1) G

Ex d e ib mb [ia Ga] IIC T4 Gb

Certificate numbers

Baseefa 09 ATEX0184U

IECEX BAS09.0081U

Safety description (spurs)

$U_o = 17.5V$

$I_o = 248mA$

$P_o = 982mW$

$C_i = 0$

$L_j = 0$

Spurs in accordance with FISCO standard IEC 60079-27

ENVIRONMENTAL

Ambient temperature (inside selected enclosure)

Operating	Storage
-40°C ... +75°C	-40°C ... +75°C

Relative humidity

< 95%, non-condensing

Electromagnetic compatibility

EN 61326 – 1:2006

NAMUR NE 21

Shock & Vibration

Vibration:

BS EN 60068-2-6: 2008 Test Fc: 1g

BS EN 60068-2-64: 1995 Test Fh: 1g

Shock:

BS EN 60068-2-27: 1993 Test Ea: 15g

MECHANICAL

Mounting position (recommended)

On to a vertical plane

Protection

Intrinsically safe terminals IP20

Non-IS terminals IP30

Weights †

MTL Part number	Weight (kg)
9387-FB	3.0
9388-FB	4.8

† includes barrier(s) and terminator but excludes any surge protection items

ORDERING INFORMATION

Order as:

9387-FB-xx 6-spur Fieldbus Barrier system with **one** 6-spur 9377-FB module installed.

9388-FB-xx 12-spur Fieldbus Barrier system with **two** 6-spur 9377-FB modules installed.

Where **xx** = PS (pluggable screw terminal connectors) PC (pluggable spring clamp connectors)

(Note: All assemblies are pre-wired and include a 9378-FT Fieldbus terminator module)

9377-FB Fieldbus Barrier 6-spur, pluggable module

9378-FT Fieldbus terminator

9376-SP Trunk surge protection module

FS32 Spur surge protection module

The given data is only intended as a product description and should not be regarded as a legal warranty of properties or guarantee. In the interest of further technical developments, we reserve the right to make design changes.



EUROPE (EMEA): +44 (0)1582 723633
enquiry@mtl-inst.com

THE AMERICAS: +1 800 835 7075
csinfo@mtl-inst.com

ASIA-PACIFIC: +65 6 487 7887
sales@mtlsing.com.sg

EPS 9370-FB-1 021111

DIMENSIONS (mm)

9387-FB-xx 6-way baseplate assembly

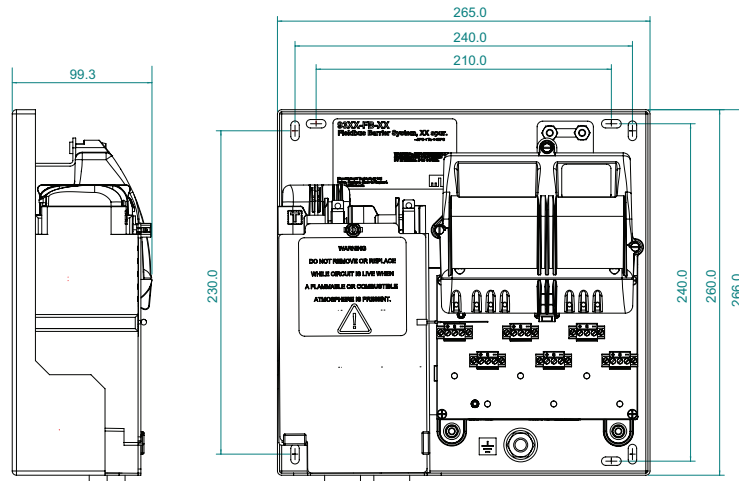

Mounting slot size 14 x 6

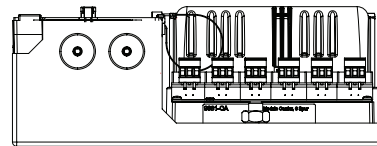

9388-FB-xx 12-way baseplate assembly

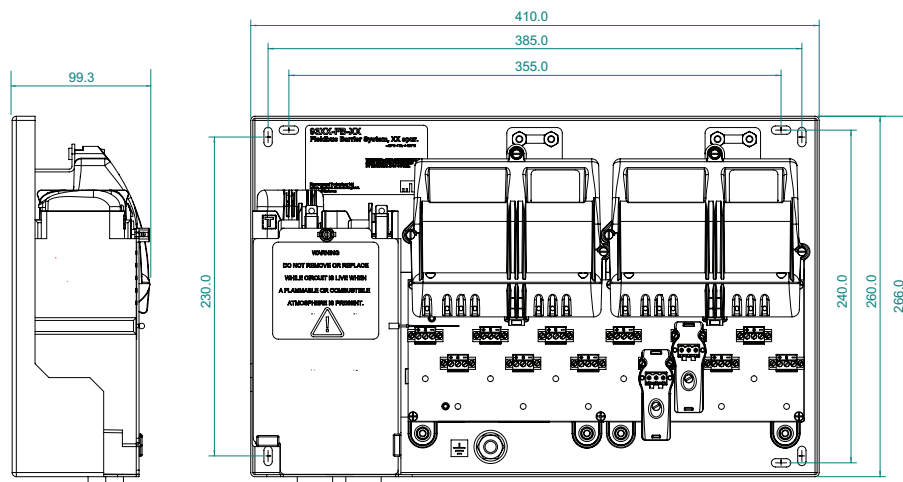

Mounting slot size 14 x 6

