

Sieger System 57

1 Contents

1 Contents.....	1
2 Safety.....	2
3 Introduction.....	3
3.1 Gas Control Cards.....	3
3.2 Fire Control Cards.....	3
3.3 Master Alarm Update Panel.....	3
3.4 Power Supply Units.....	3
3.5 Engineering Card.....	4
3.5.1 Serial Communications Module.....	4
3.5.2 RS232 Printer Driver Module.....	4
3.5.3 Master Alarm Update Module.....	4
3.6 Interface Cards.....	4
3.7 Rack Assemblies.....	4
3.8 Cabinet Assemblies.....	4
3.9 DC Input Card.....	5
4 System Overview.....	6
5 Cabinet and Rack Installation.....	7
6 Detector Installation.....	7
7 Interface Card Connections.....	8
8 Detector Connections.....	9
8.1 Cable Earthing/Grounding.....	9
8.2 5701 Gas Card and Catalytic Type Detector.....	9
8.3 5701 Gas Card and 2 Wire Loop Powered Detectors.....	9
8.3.1 4-20mA loop powered detector (measuring resistor in supply return).....	10
8.3.2 4-20mA loop powered detector (measuring resistor in supply positive line).....	10
8.4 5701 Gas Card and 3 Wire 4-20mA Transmitter.....	10
8.4.1 3 Wire Source Transmitter (sink card).....	11
8.4.2 3 Wire Sink Transmitter (source card).....	11
8.5 5704 Gas Card and Catalytic Type Detector.....	12
8.6 5704 Gas Card and 2 Wire Loop Powered Detectors.....	12
8.6.1 4-20mA loop powered detector (measuring resistor in supply return).....	12
8.7 5704 Gas Card and 3 Wire 4-20mA Transmitter.....	13
8.8 5704 Fire Card.....	14
8.8.1 Line Resistance.....	14
8.8.2 Typical Loop Powered Detector Connections.....	15
8.8.3 Typical Loop Powered Detector with IS Barrier Connections.....	15
8.8.4 Separately Powered Detectors.....	16
8.8.5 Call Points and Simple Switched Output Detectors.....	17
8.8.6 Detectors with Voltage Free Contact Outputs.....	18
9 Specification.....	20
9.1 Approvals and Standards.....	20
9.2 Environmental.....	21
9.3 RFI/EMC Conformity.....	21
10 Special Conditions For Safe Use.....	22

2 Safety

Ensure that you read and understand these instructions **BEFORE** operating the equipment. Please pay particular attention to the Safety Warnings.

WARNINGS

The items of equipment covered by this manual are:

1. Not designed or certified for use in hazardous areas.
2. Designed for indoor use only.
3. Not to be exposed to rain or moisture.

CAUTIONS

1. Use only approved parts and accessories with the System 57 control system.
2. To maintain safety standards, regular maintenance, calibration and operation of the System 57 control system by qualified personnel is essential.

IMPORTANT NOTICES

1. Honeywell Analytics can take no responsibility for installation and/or use of its equipment if this is not done in accordance with the appropriate issue and/or amendment of the manual.
2. The user of this manual should ensure that it is appropriate in all details to the exact equipment to be installed and/or operated. If in doubt, the user should contact Honeywell Analytics for advice.

Honeywell Analytics reserve the right to change or revise the information supplied in this document without notice and without obligation to notify any person or organisation of such revision or change. If further details are required which do not appear in this manual, contact Honeywell Analytics or one of their agents.

3 Introduction

System 57 is a fire and or gas control system offering great flexibility through its modular construction. The system is constructed in a rack that can be fitted with fire and/or gas control cards and corresponding interface cards that allow connection of the associated detectors. The rack can be panel or cabinet mounted. Further details of the main components are given below. A graphical overview of all the available components and how they can be assembled into a system is shown in section X. For further detailed information refer to the individual operating manuals 05701-M-5001 (5701 gas control card), 05704-M-5001 (5704 gas control card) and 05704-M-5002 (fire control card).

3.1 Gas Control Cards

The System 57 gas control cards provide display and alarm facilities for the full range of Sieger gas detectors. Their back lit, multi-part LCD displays the gas reading and status in both analogue bar graph and digital numeric forms. In addition, there is an alpha numeric message section to give detector (and engineering function) status.

There is a choice of either the single channel 5701 or the four channel 5704 gas control cards. Each card has two input options; one is for catalytic bridge type while the other is for 4 to 20mA detectors or transmitters. The control cards feature 3 levels of alarm, options of individual, zoned, voted, master, time delayed, update and rate of rise alarm facilities, 4 part LCD display, peak reading facility and detector performance monitoring.

3.2 Fire Control Cards

The 5704F fire control cards provide display and alarm facilities for a wide variety of fire detection products and provide up to four fire zone inputs compatible with most flame, smoke and heat detectors and manual call points. The status of each fire zone is individually displayed by high intensity LEDs. In addition, each card has two line monitored alarm output circuits. Both fire and gas control cards can be freely mixed in a rack. Up to 60 fire zones can be monitored per 19" rack.

Each rack that contains a 5704F fire card has one 5704FS fire status panel fitted. The 5704FS fire status panel provides common display and alarm indication for all of the fire cards in a rack as well as a local audible sounder. It also provides common push buttons for executing specific fire card related functions.

3.3 Master Alarm Update Panel

The master alarm update facility can be enhanced by adding the optional master alarm update panel which enables update facilities without the need for external wiring. The alarm update panel is 1" wide and provides audible and visual alarms and a reset and accept push button.

3.4 Power Supply Units

The power supply units are rack mounted to match the main control card rack design. The units are 1U high, and available in 19" & ½ 19" sizes. Total maximum power capability is 200W (built in 50W blocks). The input voltage is auto sensing (AC or DC) and the output is regulated DC with over voltage and overload protection.

3.5 Engineering Card

The System 57 engineering card provides full maintenance and set up facilities for each channel card. The front panel has a series of tactile feedback push buttons that allows checks of the alarm levels and performance to be carried out for each channel. A real-time 'on board' clock provides calibration history and calibration overdue reminder functions. An access key provides security protection.

The engineering card can be fitted with optional modules for extended system options.

3.5.1 Serial Communications Module

The serial communications module provides a gateway between the System 57 rack and a remote device (DCS, PLC or SCADA package) to allow the continuous monitoring of each channel's operation and condition as well as allowing remote configuration of the system operation. The module uses the industry standard MODBUS RTU protocol, RS485/422/232 standard. Custom designed SCADA graphics packages are also available.

3.5.2 RS232 Printer Driver Module

The printer driver module provides a serial output in the event of a gas alarm, fault or user intervention. The output is RS232 ASCII event data, has selectable print criteria, provides time and date stamping and is electrically isolated.

3.5.3 Master Alarm Update Module

The alarm update module provides a common alarm indication with new alarm event update. It also provides 2 Outputs: 1 relay, 1 Darlington, with selectable operation: pulsed or continuous and an alarm and common alarm reset input. It complies with ISA 'M', DIN 19 235. It can be used with the optional master alarm update panel.

3.6 Interface Cards

There are 9 versions of interface card available (5 for 5701 Gas, 2 for 5704 Gas and 2 for 5704 Fire Control Cards). The interface cards provide the link between the various fire or gas detectors and the control cards. They provide detector interface, offer flexible relay options, and allow an individual control card power option. A high integrity relay operation version is also available. The terminals accept $\leq 2.5\text{mm}^2$ (14AWG) gauge cable.

3.7 Rack Assemblies

System 57 racking units provide mounting options for the system 57 control cards and interface cards. The racks are available complete with a DC input card and an engineering card. The racks are 3U high, with front or rear wiring options. Half and full 19" versions are available accommodating up to a maximum of 64 channels of gas detection or 60 channels of fire detection in a single rack, or a combination of both.

3.8 Cabinet Assemblies

The System 57 cabinets provide a convenient and compact mounting of the rack assemblies and PSUs. They are wall mounting and available in half and full 19" versions. The cabinets have an IP54/Nema 12 ingress protection rating, pre-formed bottom-entry knock-out gland entries and an accessory mounting plate.

3.9 DC Input Card

The DC input card is connected directly to the engineering card and provides the connection point for power supplied to the whole rack. The field wiring from the engineering card is also on this card. It provides a common power supply wiring point, reverse polarity and short circuit protection and multi-supply input capability.

4 System Overview

Key:

- ‡ Front Access Rack ‡
(inc. Eng & DC i/p cards)
19" (16 way) 05701-A-0501
or
1/2 19" (8 way) 05701-A-0502
- + Common units
- + Optional
- * FIRE addition

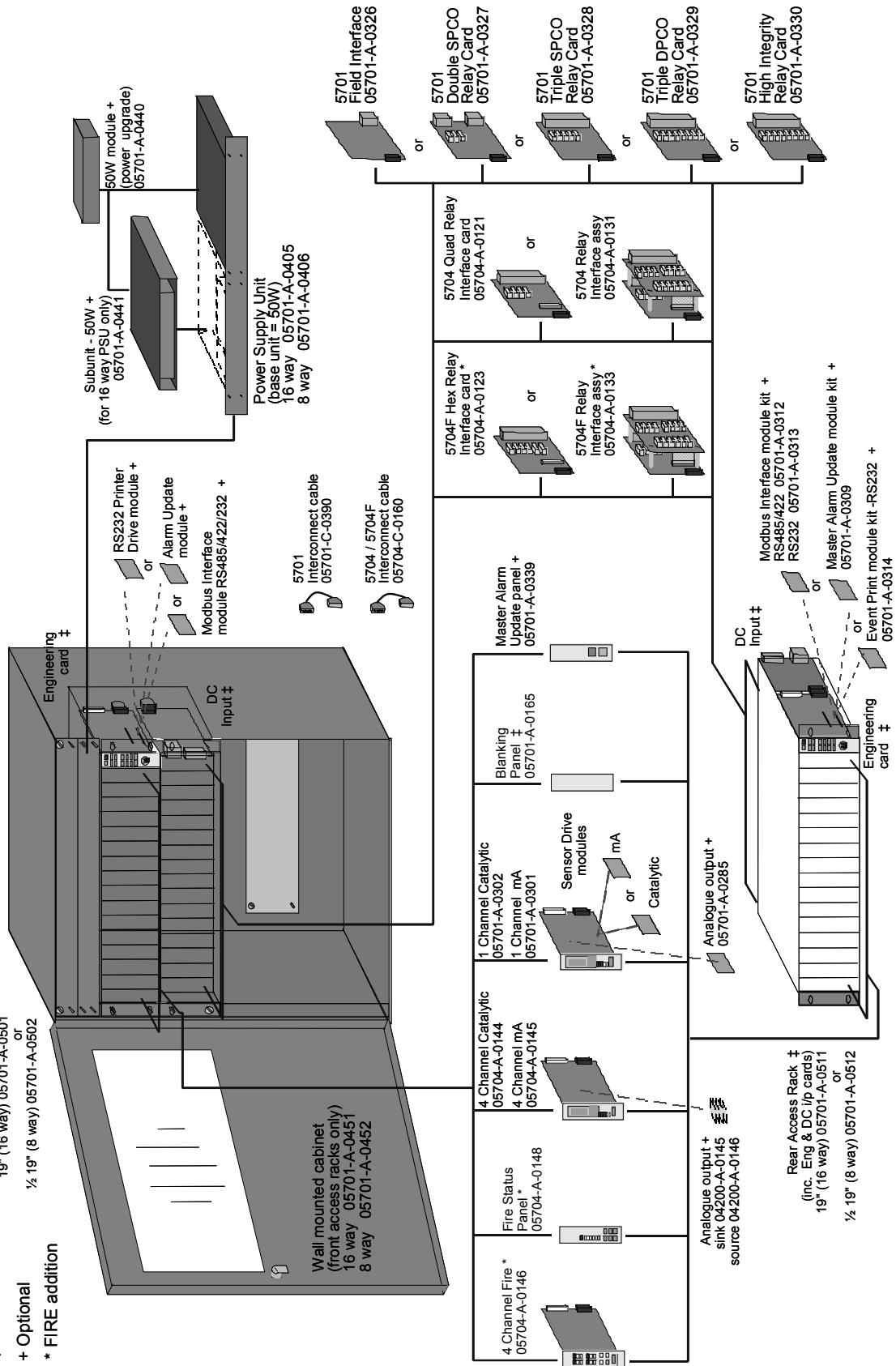

5 Cabinet and Rack Installation

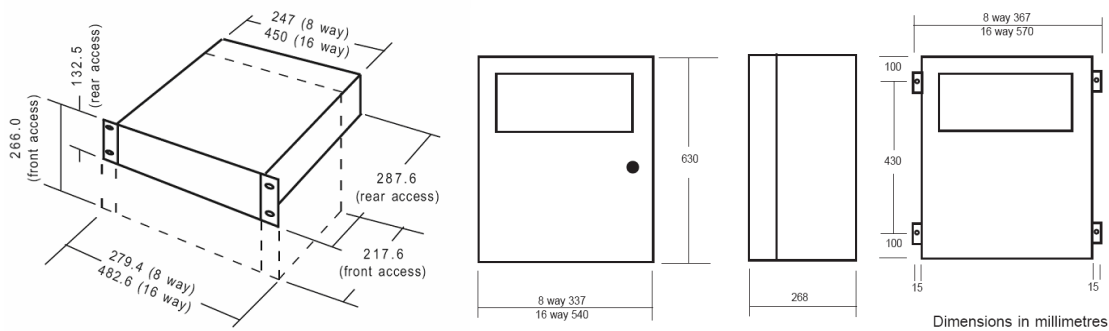

Rear and front access racks outline dimensions

Cabinet outline dimensions

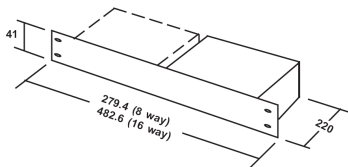

Power supply outline dimensions

6 Detector Installation

Always install the detectors in accordance with the Detector Operating Instructions. In general, detectors for lighter than air gasses should be located at a high level and detectors for heavier than air gasses should be located at a low level.

Do not install the detectors:

- a. Where the normal air flow may be impeded.
- b. In corners of rooms where static air pockets may exist.
- c. Near sources of heat such as convector heaters.

Do install the detectors:

- a. As close as possible to the potential source of gas to be detected in order to give the maximum possible warning.
- b. So that they are accessible for maintenance work.

7 Interface Card Connections

System 57 interface cards use a common card with differing numbers of terminal blocks fitted according to which type of card it is. The picture below illustrates a card with the maximum number of terminals fitted. The tables show the terminal connections for 5701, 5704 gas and 5704 fire interface cards.

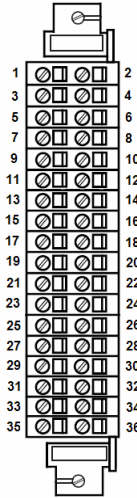

5701 Gas			
Interface Relay Card Terminals			
1	Fault NC	2	Fault NO
3	Fault COM	4	Inhibit COM
5	Inhibit NC	6	Inhibit NO
7	A1(1) NC	8	A1(1) NO
9	A1(1) COM	10	A2(1) COM
11	A2(1) NC	12	A2(1) NO
13	A3(1) NC	14	A3(1) NO
15	A3(1) COM	16	A1(2) COM
17	A1(2) NC	18	A1(2) NO
19	A2(2) NC	20	A2(2) NO
21	A2(2) COM	22	A3(2) COM
23	A3(2) NC	24	A3(2) NO
25	Ground	26	Ground
27	Sensor S	28	Sensor 01
29	Sensor NS	30	Not Connected
31	Analogue O/P(+)	32	Analogue O/P (-)
33	Remote Inhibit In	34	Remote Reset In
35	+24V (Out/In)	36	0V (Out/In)

5704 Gas			
Quad Relay Card Terminals		Expansion Relay Card Terminals	
1	Relay 1 NC	2	Relay 1 NO
3	Relay 1 COM	4	Relay 2 COM
5	Relay 2 NC	6	Relay 2 NO
7	Relay 3 NC	8	Relay 3 NO
9	Relay 3 COM	10	Relay 4 COM
11	Relay 4 NC	12	Relay 4 NO
13	Ground	14	Ground
15	Channel 1 (S)	16	Channel 2 (S)
17	Channel 1 (01)	18	Channel 2 (01)
19	Channel 1 (NS)	20	Channel 2 (NS)
21	Channel 3 (S)	22	Channel 4 (S)
23	Channel 3 (01)	24	Channel 4 (01)
25	Channel 3 (NS)	26	Channel 4 (NS)
27	Analogue 24V	28	Analogue 0V
29	Analogue CH1	30	Analogue CH2
31	Analogue CH3	32	Analogue CH4
33	Remote Reset	34	Remote Inhibit
35	+24V (In)	36	0V (In)
1	Relay 5 NC	2	Relay 5 NO
3	Relay 5 COM	4	Relay 6 COM
5	Relay 6 NC	6	Relay 6 NO
7	Relay 7 NC	8	Relay 7 NO
9	Relay 7 COM	10	Relay 8 COM
11	Relay 8 NC	12	Relay 8 NO
13	Relay 9 NC	14	Relay 9 NO
15	Relay 9 COM	16	Relay 10 COM
17	Relay 10 NC	18	Relay 10 NO
19	Relay 11 NC	20	Relay 11 NO
21	Relay 11 COM	22	Relay 12 COM
23	Relay 12 NC	24	Relay 12 NO
25	Relay 13 NO	26	Relay 13 COM
27	Relay 14 NO	28	Relay 14 COM
29	Relay 15 NO	30	Relay 15 COM
31	Relay 16 NO	32	Relay 16 COM
33	Ground	34	Ground
35	Not Used	36	Not Used

5704 Fire			
Hex Relay Card Terminals		Relay Interface Card Terminals	
1	Relay 1 NC	2	Relay 1 NO
3	Relay 1 COM	4	Relay 2 COM
5	Relay 2 NC	6	Relay 2 NO
7	Relay 3 NC	8	Relay 3 NO
9	Relay 3 COM	10	Relay 4 COM
11	Relay 4 NC	12	Relay 4 NO
13	Relay 5 NC	14	Relay 5 NO
15	Relay 5 COM	16	Relay 6 COM
17	Relay 6 NC	18	Relay 6 NO
19	Ground	20	Ground
21	Input CH1 (+)	22	Input CH2 (+)
23	Input CH1 (-)	24	Input CH2 (-)
25	Output CH1 (+)	26	Output CH1 (-)
27	Input CH3 (+)	28	Input CH4 (+)
29	Input CH3 (-)	30	Input CH4 (-)
31	Output CH2 (+)	32	Output CH2 (-)
33	Remote Input (+)	34	Remote Input (-)
35	+24V (Out/In)	36	0V (Out/In)
1	Relay 5 NC	2	Relay 5 NO
3	Relay 5 COM	4	Relay 6 COM
5	Relay 6 NC	6	Relay 6 NO
7	Relay 7 NC	8	Relay 7 NO
9	Relay 7 COM	10	Relay 8 COM
11	Relay 8 NC	12	Relay 8 NO
13	Relay 9 NC	14	Relay 9 NO
15	Relay 9 COM	16	Relay 10 COM
17	Relay 10 NC	18	Relay 10 NO
19	Relay 11 NC	20	Relay 11 NO
21	Relay 11 COM	22	Relay 12 COM
23	Relay 12 NC	24	Relay 12 NO
25	Relay 13 NO	26	Relay 13 COM
27	Relay 14 NO	28	Relay 14 COM
29	Relay 15 NO	30	Relay 15 COM
31	Relay 16 NO	32	Relay 16 COM
33	Ground	34	Ground
35	Not Used	36	Not Used

8 Detector Connections

The following sections show generic installation schematics for the most common types of fire or gas detector and System 57.

8.1 Cable Earthing/Grounding

The detector cable screen or steel wire armour (or braid), as appropriate, should be connected to the system (protective) earth. This can be achieved where the cable enters the cabinet by using a metal cable gland, or by other suitable means, and avoiding any screen 'tails' within the cabinet.

Where the cable consists of a separate screen sheath and wire armour (or braid), the armour should be connected, at the cabinet entry, to the protective earth and the screen sheath should be connected to the GROUND terminal of the Field Interface/Relay Card or to a suitable instrument earth point.

Note: Where a detector is earthed locally, either to the Earth Stud or through the detector casing or mounting, to avoid earth loops the screen sheath of the cable should only be connected at one end, i.e., at the detector or at the Interface/Relay Card.

8.2 5701 Gas Card and Catalytic Type Detector

Catalytic detectors require a three wire connection and the detector documentation will indicate three connections S, 01 and NS, which are usually brown, white and blue respectively. At the System 57 end of the field cable, the three detector wires should each be connected to the respective matching S, 01 or NS terminal on the Field Interface or Relay Card that is attached to the required Single Channel Display Card.

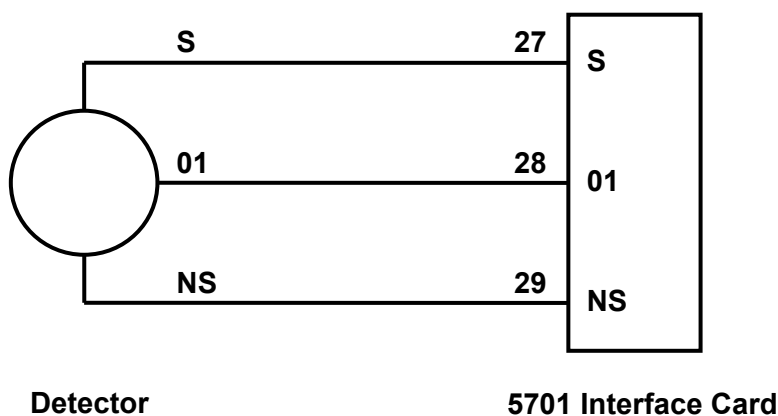

8.3 5701 Gas Card and 2 Wire Loop Powered Detectors

Loop powered detectors require a two wire connection and the detector documentation will indicate the positive and negative loop connections, usually brown and blue respectively. At the System 57 end of the field cable the two detector wires should each be connected to one of either the S, 01 or NS terminals on the Field Interface or Relay Card that is attached to the required Single Channel Display Card. The two terminals used will vary depending upon whether the location of the measuring resistance is in the loop supply or return paths.

8.3.1 4-20mA loop powered detector (measuring resistor in supply return)

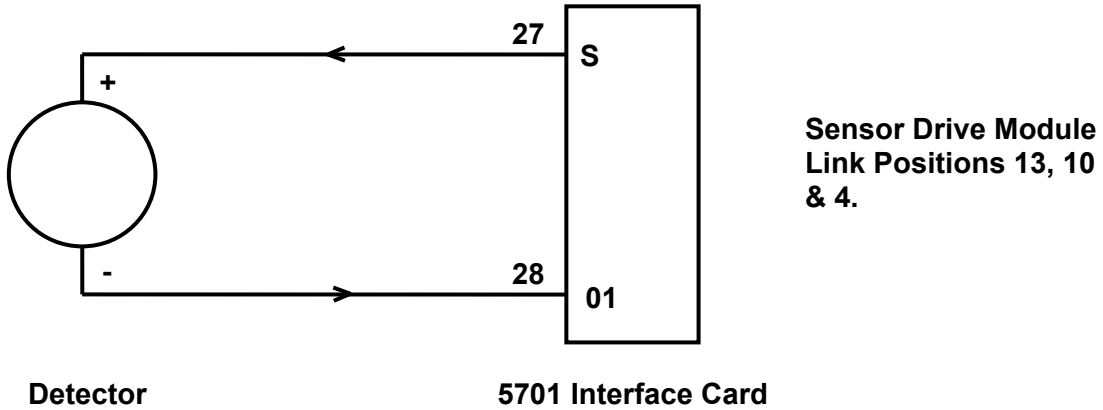

8.3.2 4-20mA loop powered detector (measuring resistor in supply positive line)

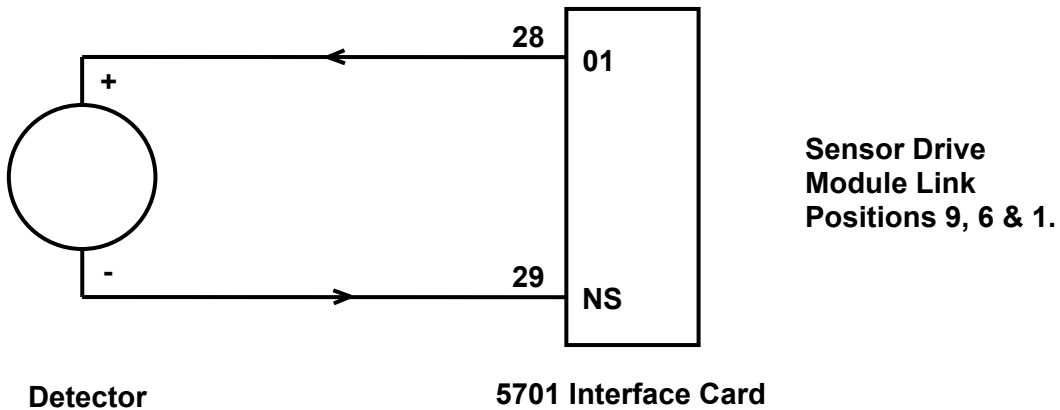

8.4 5701 Gas Card and 3 Wire 4-20mA Transmitter

CAUTION

The power provided by the Single Channel Control Card is derived from the dc input to the System 57 (18V to 32V). Check that the transmitter to be connected is compatible with the actual supply voltage used.

The maximum current that may be sourced from the field terminals of an individual Single Channel Control Card to power a field device is 500mA, however, the total current sourced from all the channels should not exceed the maximum backplane load current of 8A.

Transmitters powered from the 5701 Control Card require either three or four wire connections and the detector documentation will indicate the 0V and +24V power connections and the positive and negative loop connections.

At the System 57 end of the field cable the detector wires should be connected to the S, 01, NS, 0V or 24V terminals on the Field Interface or Relay Card that is attached to the required Single Channel Display Card. The exact terminals used vary depending upon whether three or four wire topology is used, and the requirement for loop current source or sink configuration. The Schematics below detail the connections for 3 wire current sink or source transmitters. For other schematics (including isolated and barrier) refer to operating manual 05701-M-5001.

8.4.1 3 Wire Source Transmitter (sink card)

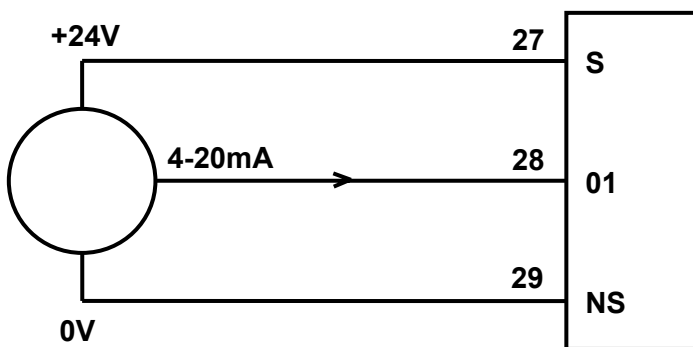

**Sensor Drive
Module Link
Positions 12, 10,
7 & 3**

Transmitter

5701 Interface Card

8.4.2 3 Wire Sink Transmitter (source card)

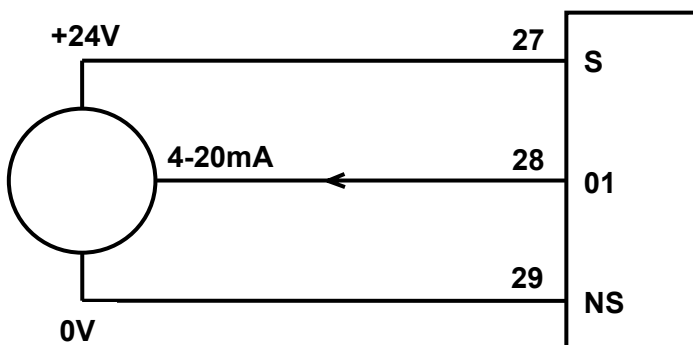

**Sensor Drive
Module Link
Positions 12, 9,
6, 3 & 1.**

Transmitter

5701 Interface Card

8.5 5704 Gas Card and Catalytic Type Detector

Catalytic detectors require a three wire connection and the detector documentation will indicate three connections S, 01 and NS, which are usually brown, white and blue respectively. At the System 57 end of the field cable, the three detector wires should each be connected to the respective matching S, 01 or NS terminal of the appropriate channel on the Quad Relay Interface Card that is attached to the required Four Channel Control Card.

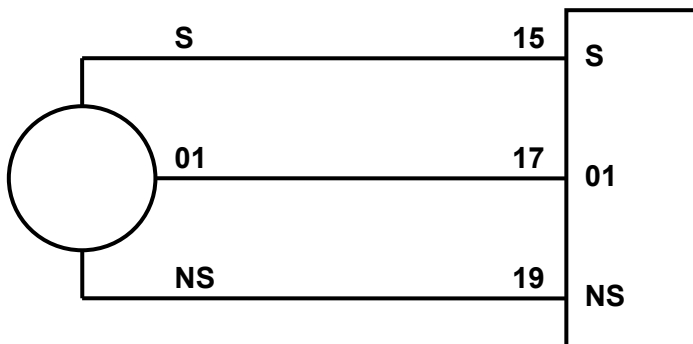

Detector

5704 Quad Card

The diagram shows the detector connections for Channel 1. Channel 2, 3 and 4 connections are similar and their terminal connection numbers are shown in section 7.

8.6 5704 Gas Card and 2 Wire Loop Powered Detectors

Loop powered detectors require a two wire connection and the documentation will indicate the positive and negative loop connections, usually brown and blue respectively. At the System 57 end of the field cable the two detector wires should be connected to the S (positive) and 01 (negative) terminals of the appropriate channel on the Quad Relay Interface Card that is attached to the required Four Channel Control Card.

8.6.1 4-20mA loop powered detector (measuring resistor in supply return)

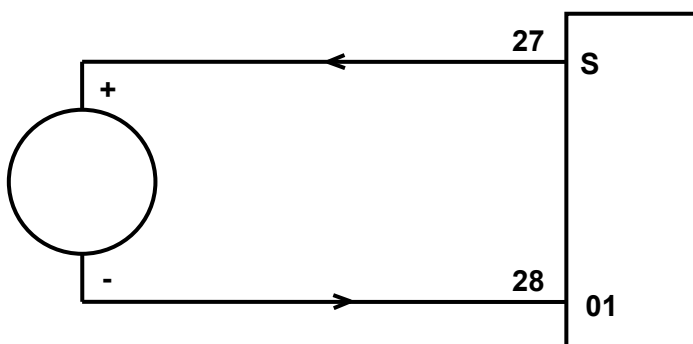

Detector

5704 Quad Card

The diagram shows the detector connections for Channel 1. Channel 2, 3 and 4 connections are similar and their terminal connection numbers are shown in section 7.

8.7 5704 Gas Card and 3 Wire 4-20mA Transmitter

Transmitters require either three or four wire connections and the detector documentation will indicate the 0V and +24V power connections and the positive and negative loop connections. At the System 57 end of the field cable the detector loop signal wires should be connected to the S, 01, NS terminals on the Quad Relay Interface Card that is attached to the required Four Channel Control Card. The exact terminals used vary depending upon whether three or four wire topology is used, the requirement for a loop current source configuration and the channel to be connected to. The transmitter power connection +24V and 0V should be connected to a suitable dc supply.

Note: Terminals 35 and 36 on the Relay Interface Card are input terminals only and cannot be used to power the transmitter.

The Schematic below details the connections for 3 wire current source transmitters. For other schematics (including isolated and barrier) refer to operating manual 05704-M-5001.

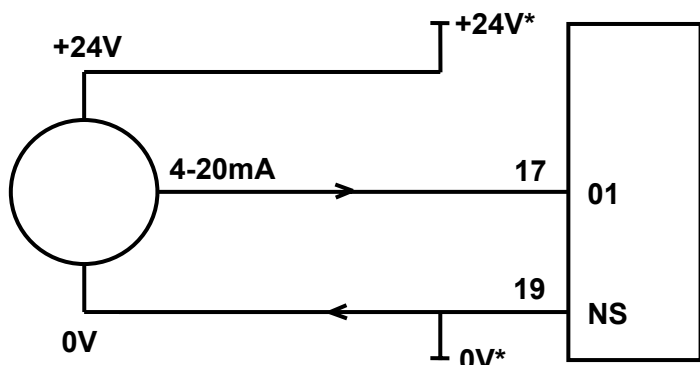

*24V supply may be obtained from either the cabinet or a separate field supply.

Transmitter

5704 Quad Card

The diagram shows the detector connections for Channel 1. Channel 2, 3 and 4 connections are similar and their terminal connection numbers are shown in section 7.

8.8 5704 Fire Card

The 5704F fire input circuit operates from the system dc input supply (21 to 32V) but has a built-in voltage limiter that limits the maximum loop voltage to +24V to protect the detectors from damage. When the system supply is less than +24V the limiter has no effect and the loop will see the true input supply voltage. The loop current is determined by measuring the voltage across a 220 ohm current sense resistor. A link selectable 330 ohm barrier equivalent resistance is incorporated for use when an external IS barrier is NOT fitted. For fault monitoring purposes, an end of line (EOL) resistor must be fitted in or after the last detector on the loop. The typical value for the end of line resistance is 5.1k ohms although this may need to be reduced when many detectors are fitted onto the loop.

An equivalent circuit of one fire input together with an example detector connection is shown below:-

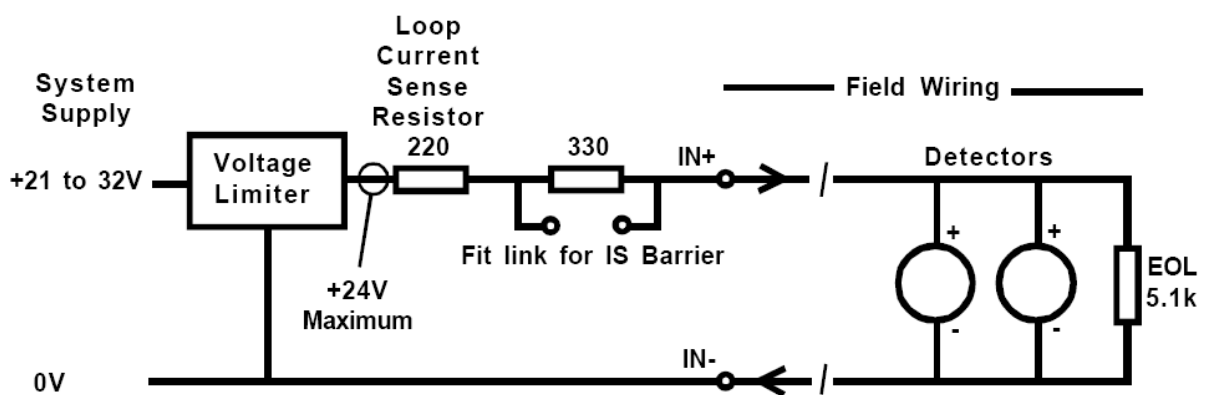

8.8.1 Line Resistance

Detectors should be located such that the line resistance of the cable required does not prevent correct operation. As a general guide and for a typical installation of twenty low quiescent current detectors, the loop cable resistance should be kept below 100 ohms total (50 ohms per core). The table below gives a quick guide to the maximum cable lengths permitted in this case:

Maximum Cable Length (m)					
Detectors	Conductor Cross Sectional Area				
AWG	21	19	18	16	14
mm ²	0.50	0.75	1.00	1.50	2.50
20 low quiescent (100µA) detectors	1300	2000	2700	4100	6500

For further details of line resistance calculation refer to the 5704F Fire Card manual 05704-M-5002.

8.8.2 Typical Loop Powered Detector Connections

Loop powered detectors (e.g. most smoke, heat and manual call points) have two wire connection. The detector documentation will indicate the positive and negative loop connections. Multiple detectors may be connected in parallel on a single loop input provided the loop operational limit for quiescent current is not exceeded.

At the System 57 end of the field cables, the two detector wires should be connected to the appropriate channels IN+ and IN- terminals of the Hex Relay Interface Card that is attached to the required 5704F Control Card. The loop current always flows from the IN+ terminal and returns via the IN- terminal.

For fault monitoring purposes an end of line (EOL) resistor must be fitted in or after the last detector on the loop. The typical value for end of line resistance is 5.1k ohms.

The detector cable screen, or steel wire armour or braid as appropriate, should be connected to the system protective earth. This can be achieved where the cable enters the cabinet by using a metal cable gland, or by other suitable means, and avoiding any screen tails within the cabinet. Where the cable consists of a separate screen sheath and wire armour or braid, the armour should be connected at the cabinet entry to the protective earth and the screen sheath should be connected to the GROUND terminal of the Hex Relay Interface Card or to a suitable instrument earth point.

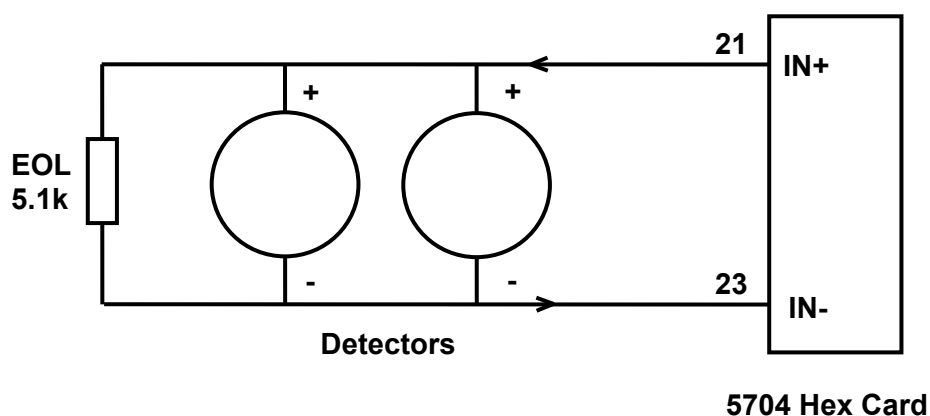

The diagram shows the detector connections for Channel 1. Channel 2, 3 and 4 connections are similar and their terminal connection numbers are shown in section 7.

8.8.3 Typical Loop Powered Detector with IS Barrier Connections

Loop powered intrinsically safe detectors (e.g. most smoke, heat and manual call points) have two wire connection. The detector documentation will indicate the positive and negative loop connections. Multiple detectors may be connected in parallel on a single loop input provided the IS criteria and loop operational limit for quiescent current are not exceeded.

In the safe area, the two wires from the detector should be connected to the field (hazardous area) side of the barrier. The input (safe area) side wires from the barrier should be connected to the appropriate channels IN+ and IN- terminals of the Hex Relay Interface Card that is attached to the required 5704F Control Card. The loop current always flows from the IN+ terminal and returns via the IN- terminal. The barrier must be earthed appropriately. For fault monitoring purposes an end of line (EOL) resistor must be fitted in or after the last detector on the loop. The typical value for end of line resistance is 5.1k ohms.

When using an external barrier the IS compatibility link for the input must be set appropriately. Intrinsically safe systems must be earthed at one point only. All detector cable screens should be connected separately to the IS safety ground.

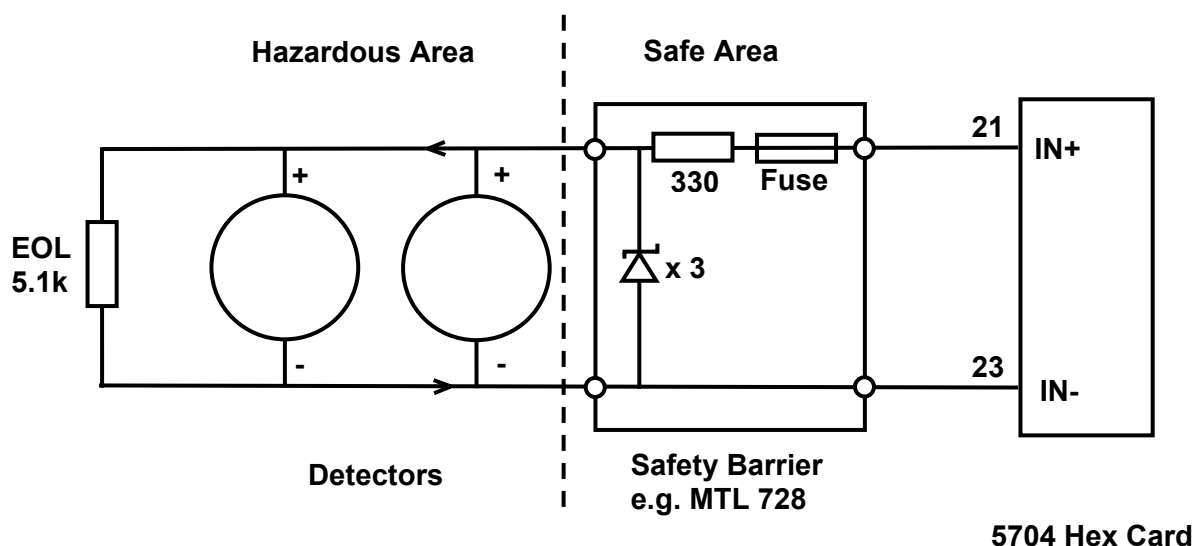

The diagram shows the detector connections for Channel 1. Channel 2, 3 and 4 connections are similar and their terminal connection numbers are shown in section 7.

Notes: 1. Earth Leakage must not be used with single or dual barriers since the 0V is connected to IS ground. If earth leakage is required an isolating barrier must be used.
2. A suitable barrier specification is a 28V 300 ohm Shunt Barrier with 50mA minimum current capability for short circuit survival.

Fire Card Link Settings:

LK150- Earth Leakage Fault Detection Enable.

Default position 1 to 2 to disable detection. Link 2 to 3 to enable the earth leakage detection circuit. **IMPORTANT:** This link should be set on one fire card only and usually the card connected to the Fire Status Panel.

LK101, 201, 301, 401- I.S. Input Compatibility.

Individual setting for inputs 1 to 4 respectively. Default position 1 to 2 for normal operation. Link 2 to 3 when using an external I.S. barrier.

8.8.4 Separately Powered Detectors

Separately powered detectors (e.g. most IR, UV/IR Flame detectors) require three or four wire connections. The detector documentation will indicate the 0V and +24V power connections and the positive and negative loop connections. When using flame detectors it is common practice to use only one detector per loop input.

At the System 57 end of the field cables the two detector signal wires should be connected to the appropriate channels IN+ and IN- terminals of the Hex Relay Interface Card that is attached to the required 5704F Control Card. The loop current always flows from the IN+ terminal and returns via the IN- terminal.

The power for the detector may be sourced from the System 57 power supply or a separate field supply, whichever is most appropriate. In small systems, power can be obtained from terminals 35 and 36 of the Hex Relay Interface Card, but care must be taken not to exceed the maximum backplane current loading of 8A. A separate dc power distribution block is recommended.

For fault monitoring purposes, an end of line (EOL) resistor must be fitted in or after the last detector on the loop. The typical value for end of line resistance is 5.1k ohms.

The detector cable screen, or steel wire armour or braid as appropriate, should be connected to the system protective earth. This can be achieved where the cable enters the cabinet by using a metal cable gland, or by other suitable means, and avoiding any screen tails within the cabinet.

Where the cable consists of a separate screen sheath and wire armour or braid, the armour should be connected at the cabinet entry to the protective earth and the screen sheath should be connected to the GROUND terminal of the Hex Relay Interface Card or to a suitable instrument earth point.

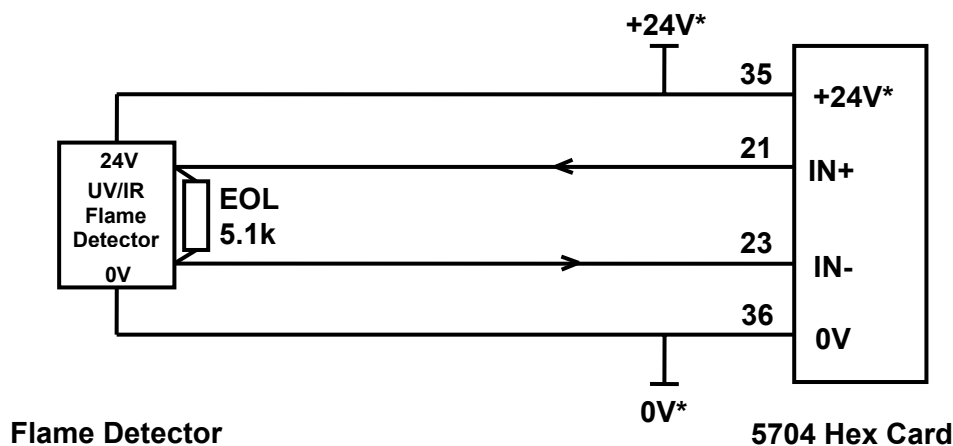

The diagram shows the detector connections for Channel 1. Channel 2, 3 and 4 connections are similar and their terminal connection numbers are shown in section 7.

Notes: 1. Separate provision may be required for power supply isolation in order to reset the detector after an alarm condition. Consult the detector operating instructions for more details.

2. For a 3 wire connection, the IN- signal can return via the 0V supply but care should be taken with the system layout to minimise electrical noise and other forms of interference.

3. Where a detector is earthed locally, either to an Earth Stud or through the sensor casing or mounting, to avoid earth loops the screen sheath of the cable should be connected at one end only.

8.8.5 Call Points and Simple Switched Output Detectors

Manually Activated Call Points (MAC) and some fire detectors have a simple switched alarm output via two wire connection. The detector documentation will indicate the switch contact connections. Many call points may be connected in parallel on a single loop input, but it is good practice to keep call points on a separate input to other types of detector.

At the System 57 end of the field cables the two call point signal wires should be connected to the appropriate channels IN+ and IN- terminals of the Hex Relay Interface Card that is attached to the required 5704F Control Card. The loop current always flows from the IN+ terminal and returns via the IN- terminal.

For fault monitoring purposes an end of line (EOL) resistor must be fitted in or after the last call point on the loop. The typical value for end of line resistance is 5.1k ohms.

The detector cable screen, steel wire armour or braid as appropriate, should be connected to the system protective earth. This can be achieved where the cable enters the cabinet by using a metal cable gland, or by other suitable means, and avoiding any screen tails within the cabinet.

Where the cable consists of a separate screen sheath and wire armour or braid, the armour should be connected at the cabinet entry to the protective earth and the screen sheath should be connected to the GROUND terminal of the Hex Relay Interface Card or to a suitable instrument earth point.

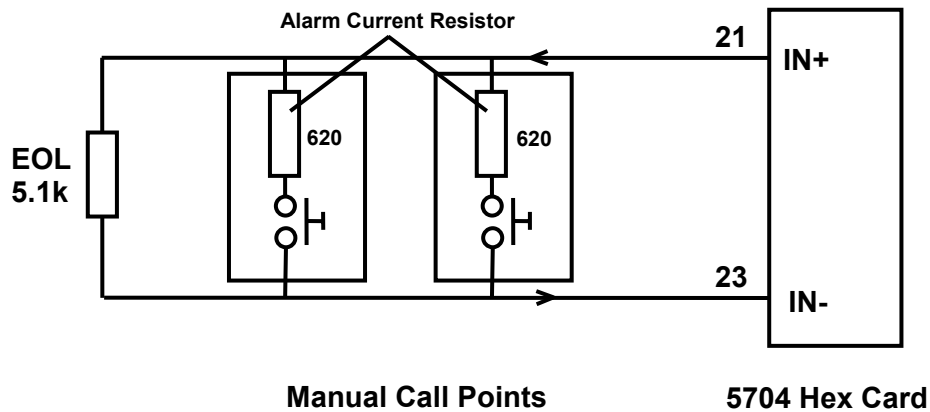

The diagram shows the detector connections for Channel 1. Channel 2, 3 and 4 connections are similar and their terminal connection numbers are shown in section 7.

- Notes:*
1. Most modern call points already incorporate the alarm current resistor, shown with a typical value of 620 ohms, if not this can be easily fitted externally within the call point junction box.
 2. The Fire Card inputs are also compatible with devices that use a zener diode, typical value 8.2V, 0.5W, to set the alarm current.
 3. The operation of more than two call points simultaneously may cause the loop current to exceed the short circuit warning threshold. This will not suppress the alarm output but a fault indication will be given on the fire card display.
 4. Where the call point is earthed locally, either to an Earth Stud or through the sensor casing or mounting, the screen sheath of the cable should be connected at one end only to avoid earth loops.

8.8.6 Detectors with Voltage Free Contact Outputs

Some fire detectors (especially flame) are equipped with a voltage free contact for the alarm output and often with a second voltage free contact for fault output. These types of detector are easily connected to the fire card using a two wire connection. The detector documentation will indicate the voltage free contact connections. Although a number of detectors may be connected in parallel on a single loop input, it is good practice to connect only one flame detector on any input.

At the System 57 end of the field cables the signal wires should be connected to the appropriate channels IN+ and IN- terminals of the Hex Relay Interface Card that is attached to the required 5704F Control Card.

The loop current always flows from the IN+ terminal and returns via the IN- terminal. For fault monitoring purposes, an end of line (EOL) resistor must be fitted in or after the last detector on the loop. The typical value for end of line resistance is 5.1k ohms.

The detector cable screen or steel wire armour or braid as appropriate, should be connected to the system protective earth. This can be achieved where the cable enters the cabinet by using a metal cable gland, or by other suitable means, and avoiding any screen tails within the cabinet.

Where the cable consists of a separate screen sheath and wire armour or braid, the armour should be connected at the cabinet entry to the protective earth and the screen sheath

should be connected to the GROUND terminal of the Hex Relay Interface Card or to a suitable instrument earth point.

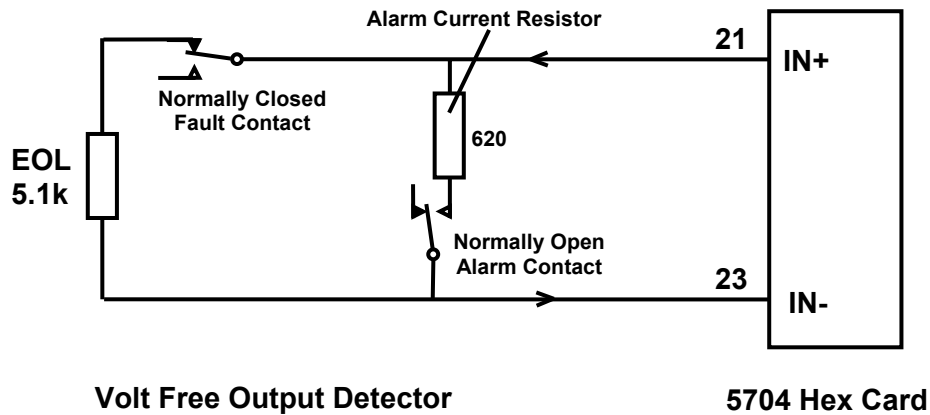

The diagram shows the detector connections for Channel 1. Channel 2, 3 and 4 connections are similar and their terminal connection numbers are shown in section 7.

*Notes: 1. Some detectors may incorporate the alarm current resistor shown with a typical value of 620 ohms, if not, this can be easily fitted externally within the detector junction box.
2. Where the detector is earthed locally, either to an earth stud or through the detector casing or mounting, to avoid earth loops the screen sheath of the cable should be connected at one end only.*

9 Specification

9.1 Approvals and Standards

Designed to comply with:

EN50054 General Requirements (Combustible Gases).

EN50057 Performance (100 LEL).

EN50058 Performance (100 V/V).

EN50271 Software and Digital Technologies.

Meets Exe isolation requirements for 50V operation.

EXAM BBG Pruef- und Zertifizier GmbH, EC-type examination certificate BVS 04 ATEX G 001 X.

Note: If compliance with the EC-type examination certificate BVS 04 ATEX G 001 X is required, refer to chapter 10 'Special Conditions for Safe Use'. Ensure that all conditions therein are met.

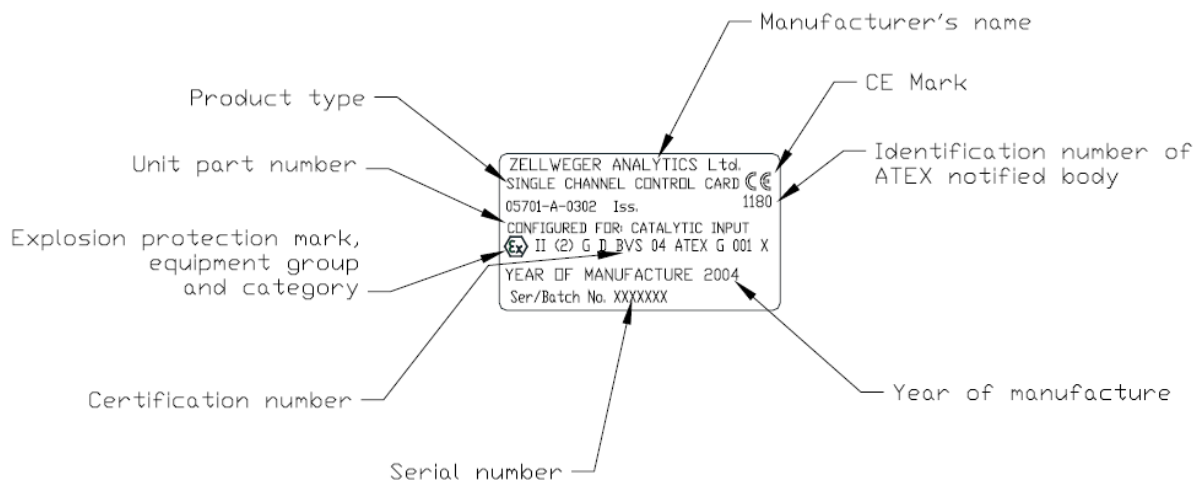

9.2 Environmental

Operating Temperature: -5°C* to +55°C (*0° for EXAM approved systems).

Storage Temperature: -25°C to +55°C.

Humidity: 0 to 90% RH. Non-condensing.

9.3 RFI/EMC Conformity

EMC Directive 89/336/EEC Conforms to: EN 50270:1999

Special conditions: The optional recorder output may be in error by $\pm 5\%$ fsd during some test conditions of the industrial standard if the connecting cables are not shielded with an outer screened cable.

Radiated Susceptibility: 10V/m over 50kHz to 1GHz. *Note: The Part 2 conformity refers to installations using the System 57 cabinet. For System 57 racks not supplied in cabinets or supplied in GRP cabinets, the conformity is to Part 1.*

LV Directive 73/23/EEC

Constructed in accordance with good engineering practice. Guided by the principles of EN61010/1 1990/1992.

10 Special Conditions For Safe Use.

ACCORDING TO EC-TYPE EXAMINATION CERTIFICATE BVS 04 ATEX G 001 X

The following special properties have to be considered at operation of the control unit:

- When operated with remote detectors with 4-20mA interface the specifications of the 4-20mA interface and the behaviour below 4mA and above 20mA have to be considered.
- The parameters "A/D-average" and "signal filter" shall be set to the detector-specific default values. Other settings shall only be used in exceptional, justified circumstances and with the manufacturer's permission. For both parameters, the lowest settings shall be used which are possible for the application.
- When configuring the control cards, the detector specific default settings should be used for the error codes "ER80", "ER81", "ER87" and "ER88" (parameters "signal over range", "signal under range", "fault over range" and "fault under range").
- The error codes "ER87", "ER88" and "ER81" (parameters "fault over range", "fault under range" and "signal under range") shall be set latching.
- When operated with remote detectors (e.g. Sensepoint) which may deliver signals within the measuring range at concentrations above the measuring range, the error code "ER80" (parameter "signal over range") shall be set latching. If the parameter is set below the default value all alarm relays shall be configured in such a way that alarming also takes place in the presence of detector faults.
- For remote detectors with 4-20mA interface the parameters "signal over range" and "fault over range" shall be set in such a way that during normal operation (including the application of 100 % gas to the remote detector) "ER80" can be activated but not "ER87".
- The analogue outputs should be operated with live zero (4-20mA setting). The "< 4mA clipping" feature should be activated only in exceptional cases. Irrespective of the operating mode of the analogue output, the "fault level" and "inhibit level" shall be configured to different values outside the measuring range. The signaling of faults and inhibits at the analogue output shall be activated.
- If no local inhibit relays are configured, a master inhibit relay shall be configured.
- If no local fault relays are configured, a master fault relay shall be configured.
- When relays are used for signaling update alarms, no other alarms or messages must be allocated to them. Configuration of update messages for "inhibit" should be avoided.
- Time delayed relays shall not be used.
- The status of the control unit obtained via Modbus shall be used only for the purpose of visualisation or documentation but not for safety purposes. Write access via Modbus shall be avoided. This certificate is concerned solely with information which can be obtained from Modbus functions 02 and 04.
- When a control card 5701 is configured for master or voted alarms as well as master or voted fault or inhibit messages, high integrity relay cards should be used. If no high integrity relay cards are used, triple relay cards shall be used. In such cases, both the relays and the LEDs of this control card will reflect only the status of the master or voting group. For an "X out of Y" linkage with vote counts (X) > 1, local alarms or messages of this control card are not displayed if less than X control cards have entered the alarm, fault or inhibit status, respectively. Therefore, voting groups have to be configured in such a way that vote counts of "1" are used for voted faults and inhibit messages to allow for signaling of local fault and inhibit states of the control card.
- Relay 1 of a high integrity relay card is always assigned to a local fault. It is also used for signaling malfunction of the high integrity relay card itself. Therefore, this relay shall be monitored for each high integrity relay card.

