

TRIO-PS/3AC/24DC/20

Primary switched power supply, 3-phase,
output current: 20 A

INTERFACE

Data Sheet

102781_01_en

© PHOENIX CONTACT - 06/2007



Description

TRIO POWER is the rail mountable 24 V power supply unit with basic functions. With an output voltage of 24 V DC and 1-phase and 3-phase versions with 60 W or 960 W, it is particularly suited for use in series production in mechanical engineering. The wide-range input and international certification package allows worldwide implementation.

The high MTBF of 500,000 h stands for high supply reliability. The devices can be connected in parallel to increase the capacity and redundancy.

The clear LED signaling and the device connection with double terminal block for plus and minus for fast potential distribution are further advantages of this device series. A third terminal block for minus simplifies the grounding on the secondary side. All power supply units are idle proof and short circuit proof and provide a regulated and settable output voltage of 22.5 V DC to 29.5 V DC with output currents of 2.5 A, 5 A, 10 A, 20 A or 40 A.

- Reliable power supply unit even at high ambient temperatures
- No load and short circuiting resistance
- High dielectric strength
- Can be used worldwide in all industrial sectors due to a wide-range input and an international approval package



DANGER OF EXPLOSION!

Remove an item only when it is not connected to power or if it is located in the non-explosive area.



DANGER

Components with dangerously high voltage and high stored energy are located in the device!

Never carry out work on live parts!

Depending on the ambient temperature and the load, the housing can become very hot!



Make sure you always use the the latest documentation.

It can be downloaded at www.download.phoenixcontact.com.

A conversion table is available on the Internet at

www.download.phoenixcontact.com/general/7000_en_00.pdf.

Table of contents

Description	1
Table of contents	2
Order data	3
Technical data.....	3
Structure	6
Block diagram	7
Safety and warning notes	7
Installation	8
Installation position.....	8
Assembly	9
Removing.....	9
Connection to various network forms.....	9
Input	10
Protection of the primary side	10
Required backup fuse (device and line protection).....	10
Output	11
Protection of the secondary side	11
Signaling	11
Function	12
Output characteristic curve	12
Thermal behavior	12
Parallel operation	13

Order data

Description	Type	Order No.	Pcs./Pkt.
Primary switched power supply, 3-phase, output current: 20 A	TRIO-PS/3AC/24DC/20	2866394	1

Accessories	Type	Order No.	Pcs./Pkt.
Universal wall adapter	UWA 182/52	2938235	1

Technical data

Input data	
Input nominal voltage range	2x / 3x 400 V AC ... 500 V AC
AC input voltage range	320 V AC ... 575 V AC (for 3-phase operation) 2x 360 V AC ... 575 V AC (for 2-phase operation)
AC frequency range	45 Hz ... 65 Hz
Current consumption	3x 1.1 A (400 V AC) 3x 0.8 A (480 V AC)
Inrush current limitation	< 15 A
I^2t	0.5 A ² s
Power failure bypass	> 17 ms (400 V AC) > 20 ms (480 V AC)
Typical response time	< 1 s
Power factor (cos phi)	0.67
Protective circuitry	Transient surge protection Varistor
Recommended backup fuse for mains protection	3x 6 A (characteristic B) 3x 10 A (characteristic B) 3x 16 A (characteristic B)
Required backup fuse (device and line protection)	(externally via 3 circuit breakers 6 A, 10 A or 16 A, characteristic B)
Discharge current to PE	< 3.5 mA

Output data	
Nominal output voltage	24 V DC \pm 1%
Setting range of the output voltage	22.5 V DC ... 29.5 V DC
Output current	20 A (-25 °C ... 55 °C)
Derating	Above +55 °C: 2.5% per Kelvin
Current limitation	Approx. 25 A
Max. capacitive load	Unlimited
Control deviation	< 1 % (change in load, static 10% ... 90%) < 2 % (change in load, dynamic 10% ... 90%) < 0.1 % (change in input voltage \pm 10%)
Power loss nominal load max.	48 W
Maximum power dissipation idling	6 W
Efficiency	> 91 %
Ascent time	< 2 ms (U_{OUT} (10% ... 90%))
Residual ripple	< 10 mV _{PP}
Peak switching voltages	< 50 mV _{PP}
Connection in parallel	Yes, for redundancy and increased capacity
Connection in series	No
Surge protection against internal surge voltages	Yes, < 35 V DC
Resistance to reverse feed	35 V DC

Signal output DC OK active

Status display "DC OK" LED green / $U_{OUT} > 21.5 \text{ V}$: LED lights up

General data

Insulation voltage input/output	4 kV AC (Type test) 2 kV AC (routine test)
Insulation voltage input / PE	2 kV AC (type test) 2 kV AC (routine test)
Insulation voltage output / PE	500 V DC (routine test)
Degree of protection	IP20
Class of protection	I, with PE connection
MTBF	> 500 000 h in acc. with IEC 61709 (SN 29500)
Housing version	Steel sheet, zinc-plated
Side element version	Aluminum
Dimensions W / H / D (state of delivery)	115 mm / 130 mm / 152.5 mm
Weight	2 kg

Ambient conditions

Ambient temperature (operation)	-25 °C ... 70 °C (> 55° C derating)
Ambient temperature (storage/transport)	-40 °C ... 85 °C
Max. permissible relative humidity (operation)	95 % (at 25°C, no condensation)
Vibration (operation)	< 15 Hz, amplitude $\pm 2.5 \text{ mm}$ in acc. with IEC 60068-2-6 15 Hz ... 150 Hz, 2.3g, 90 min.
Shock	30g in all directions in acc. with IEC 60068-2-27
Pollution degree in acc. with EN 50178	2
Climatic class	3K3 (in acc. with EN 60721)

Standards

Electrical Equipment for Machinery	EN 60204
Safety transformers for power supply units	EN 61558-2-17
Electrical safety (of information technology equipment)	EN 60950/VDE 0805 (SELV) EN 61558-2-17
Electronic equipment for use in electrical power installations	EN 50178/VDE 0160 (PELV)
SELV	EN 60950 (SELV) EN 60204 (PELV)
Safe isolation	DIN VDE 0100-410 DIN VDE 0106-1010
Protection against electric shock	DIN 57100-410
Protection against electric shock, basic requirements for safe isolation in electrical equipment	DIN VDE 0106-101
Limitation of mains harmonic currents	EN 61000-3-2

Approvals

UL rating	UL Listed UL 508 UL/C-UL Recognized UL 60950
-----------	---

Conformance with EMC directive 89/336/EEC**Immunity to interference in acc. with EN 61000-6-2**

Discharge of static electricity

Housing	Level 3
Contact discharge	6 kV
Discharge in air	8 kV
Comments	Criterion B

Electromagnetic HF field

Housing	Level 3
Frequency range	80 MHz ... 3 GHz
Field intensity	10 V/m
Comments	Criterion A

Fast transients (burst)

Input	4 kV (level 4 - asymmetrical: conductor to ground)
Output	2 kV (level 3 - asymmetrical: conductor to ground)
Comments	Criterion A

Surge current loads (Surge)

Input/Output	4 kV (level 4 - asymmetrical: conductor to ground) 2 kV (level 4 - symmetrical: conductor to conductor)
Comments	Criterion A

Conducted interference

Input/output	Level 3 - asymmetrical
Frequency range	0.1 MHz ... 80 MHz
Voltage	10 V
Comments	Criterion A

Voltage dips

Input	(mains buffering > 10 ms)
Comments	Criterion B

Emitted interference in acc. with EN 61000-6-3

Radio interference voltage in acc. with EN 55011	EN 55011 (EN 55022) Class B, area of application: Industry and residential
Emitted radio interference in acc. with EN 55011	EN 55011 (EN 55022) Class B, area of application: Industry and residential

Structure

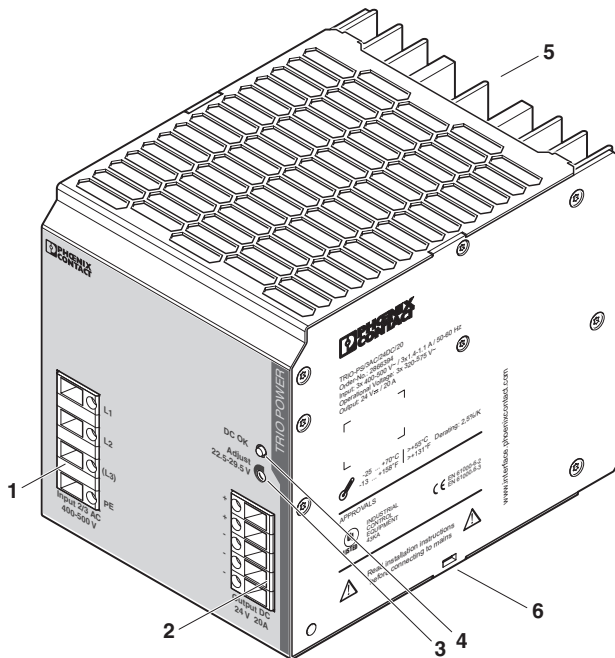

- 1 AC input
- 2 DC output
- 3 Potentiometer 22.5 V DC ... 29.5 V DC
- 4 "DC OK" LED
- 5 DIN rail adapter
- 6 Take-up for cable binders

	[mm ²]		AWG	[Nm] Torque
	solid	stranded		
Input	0.2 - 2.5	0.2 - 2.5	24 - 14	0.4 - 0.5
Output	0.5 - 6	0.5 - 4	12 - 10	0.5 - 0.6

Input data

Input nominal voltage range	2x / 3x 400 V AC ... 500 V AC
AC input voltage range	320 V AC ... 575 V AC (for 3-phase operation) 2x 360 V AC ... 575 V AC (for 2-phase operation)
AC frequency range	45 Hz ... 65 Hz
Recommended backup fuse for mains protection	3x 6 A (characteristic B) 3x 10 A (characteristic B) 3x 16 A (characteristic B)
Required backup fuse (device and line protection)	(externally via 3 circuit breakers 6 A, 10 A or 16 A, characteristic B)
Type of connection	Screw connection
Stripping length	9 mm

Output data

Nominal output voltage	24 V DC \pm 1%
Setting range of the output voltage	22.5 V DC ... 29.5 V DC
Output current	20 A (-25 °C ... 55 °C)
Type of connection	Screw connection
Stripping length	14 mm

Block diagram

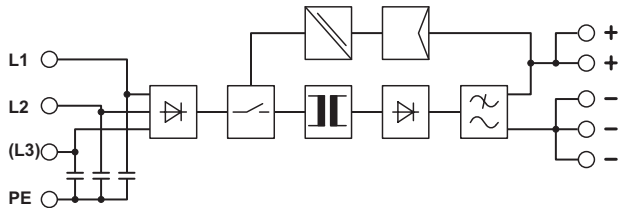

Safety and warning notes



The power supply units are built-in devices. The device may only be installed and put into operation by qualified personnel. The corresponding national regulations must be observed.



DANGER OF EXPLOSION!

Remove an item only when it is not connected to power or if it is located in the non-explosive area.

DANGER

Components with dangerously high voltage and high stored energy are located in the device!

Never carry out work on live parts!

Depending on the ambient temperature and the load, the housing can become very hot!



Before startup please ensure:

The mains connection has been carried out by a competent person and protection against electric shock is guaranteed!

The device can be disconnected outside the power supply unit in accordance with the regulations as in EN 60950 (e.g. through primary side line protection)!

The ground conductor is connected!

All feed lines are sufficiently protected and dimensioned!

All output lines are dimensioned according to the maximum output current of the device or separately protected!

Sufficient convection is guaranteed!

Installation

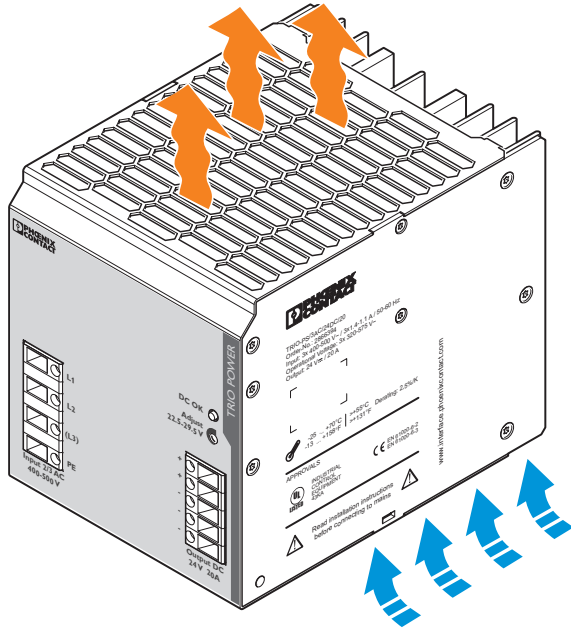

In order to guarantee sufficient convection, we recommend observing the following minimum distance to other modules: 5 cm in a vertical direction and 0 cm in a horizontal direction.



The power supply unit can be snapped onto all DIN rails in acc. with EN 60715. They must be mounted horizontally (connecting terminal blocks bottom).

Installation position

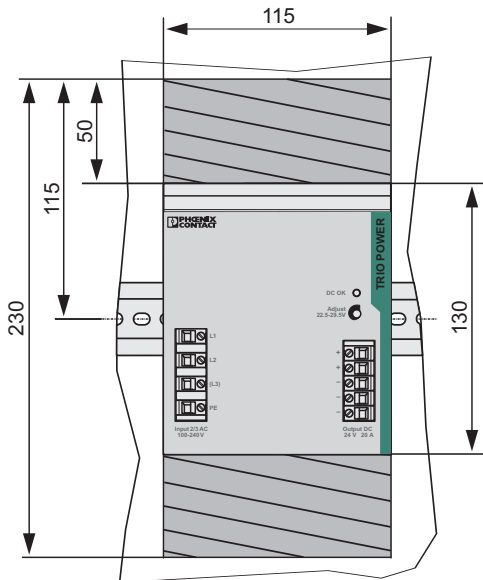

Mounting position: Installation depth 152.5 mm (+ DIN rail)

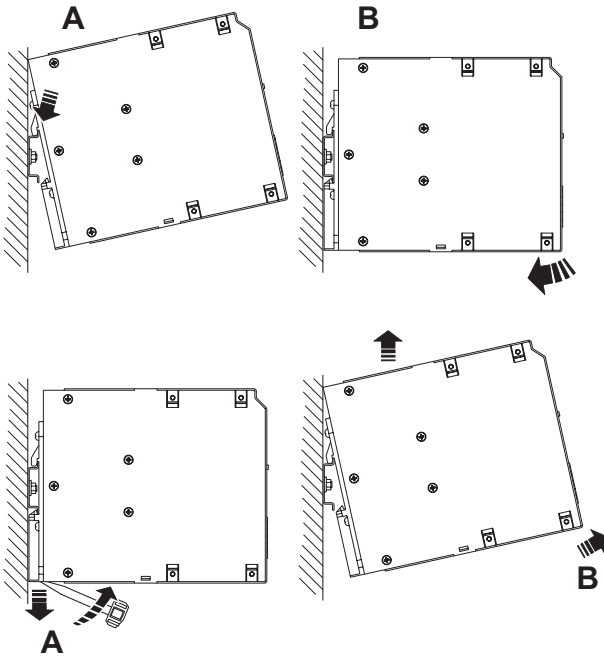

Assembly

Position the module with the DIN rail guide on the upper edge of the DIN rail, and snap it in with a downward motion.

Removing

Pull the snap lever open with the aid of a screwdriver and slide the module out at the lower edge of the DIN rail.

Connection to various network forms

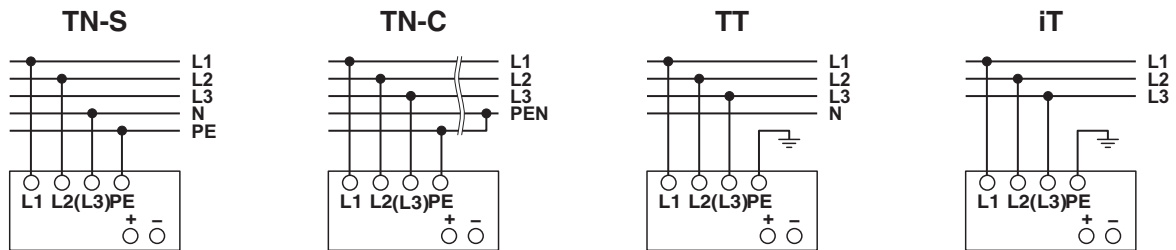

The connection for 2x/3x 400 V AC ... 500 V AC is made using the L1, L2, L3 and PE screw connections. The device can be connected to 2/3-phase AC networks with nominal voltages 2x/3x 400 V AC ... 500 V AC. In the event of a phase failure, unrestricted operation is possible with nominal capacity.



In order to comply with the UL certification, use copper cables that are designed for operating temperatures of > 75°C. In order to comply with EN 60950/UL 60950, flexible cables require ferrules. To safely connect a device, the ferrules should have a length of at least 10 mm (AC input) or 15 mm (DC output). To achieve a reliable and shock-proof connection, strip the connecting ends according to section "Structure".

Input

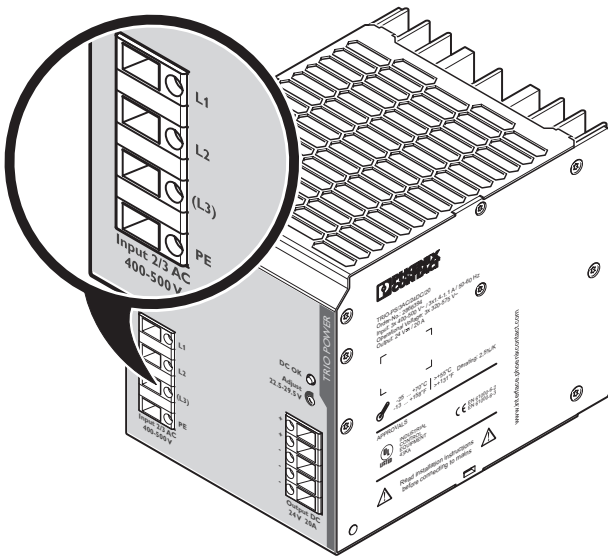

Protection of the primary side

The device must be installed in acc. with the regulations as in EN 60950. It must be possible to disconnect the device using a suitable isolating facility outside the power supply. Primary circuit mains protection, for example, is suitable for this purpose.

Required backup fuse (device and line protection)

Three external thermo-magnetic fuses are necessary as device protection: 3 x 6 A, 10 A or 16 A power circuit breaker, characteristic B (or identical function).



If an external fuse is triggered, there is most probably a malfunction in the device. In this case, the device must be inspected in the factory!

Output

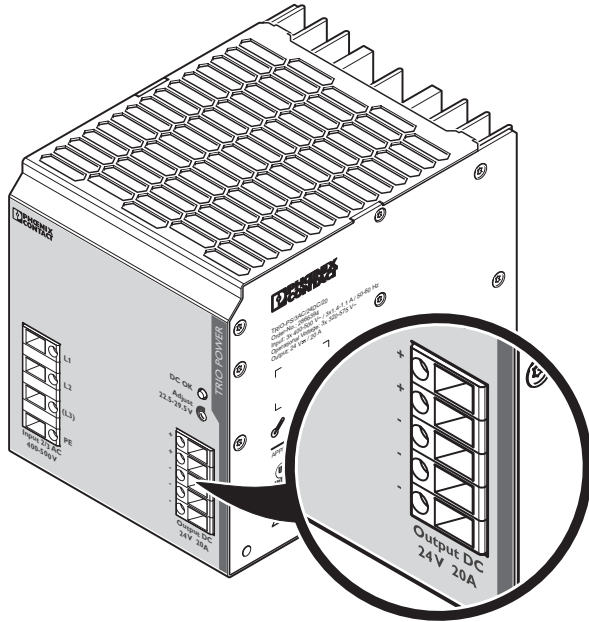

Make sure that all output lines are dimensioned according to the maximum output current or are separately protected. The cables on the secondary side must have sufficiently large cross sections in order to keep the voltage drops on the lines as low as possible.



You can fasten the connection cables to the housing using cable binders. Ensure that the cable binders and the connection cables are designed for the surface temperatures that occur in operation. Make sure that the insulation of the connection cables is not damaged when tightening the cable binders.

The connection is made using the "+" and "-" screw connections on the screw connection of the DC output. At the time of delivery, the output voltage is 24 V DC. The output voltage can be set on the potentiometer.

Protection of the secondary side

The device is electronically protected against short circuit and idling. In the event of a malfunction, the output voltage is limited to 35 V DC.

Signaling

The "DC OK" LED enables evaluation of the function of the power supply directly on site.

	State 1	State 2
"DC OK" LED	ON	OFF
Cause	Output voltage > 21.5 V	Output voltage < 21.5 V or no voltage at the output
Meaning	Output voltage and output current OK	TRIO POWER is in operation, but there is a fault on the side of the consumer; the current consumption is greater than I_N or the output is short circuited. TRIO POWER is out of operation because there is no mains voltage, the fuse on the primary side has been triggered, or the device is faulty.

Function

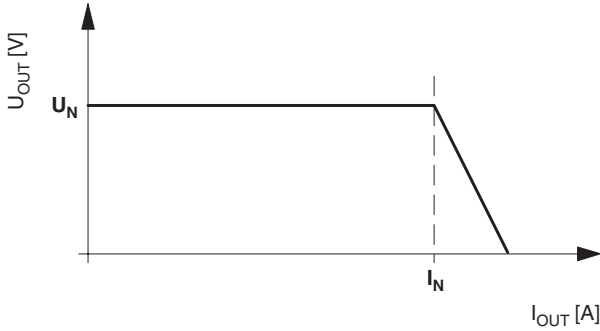

Output characteristic curve

The device functions following the U/I characteristic curve. Under load, the working point follows this curve. The output current is limited in the event of a short circuit or overload. Thereby, the device does not switch off, but rather supplies a continuous output current.

The secondary voltage is reduced until the short circuit or overload on the secondary side has been remedied. The U/I characteristic curve ensures that both heavily capacitive loads and loads with DC/DC converters in the primary circuit can be supplied. Downstream fuses are triggered. Selectivity in the design of your system is guaranteed at all times.

$U_N = 24 \text{ V}$

$I_N = 20 \text{ A}$

$P_N = 480 \text{ W}$

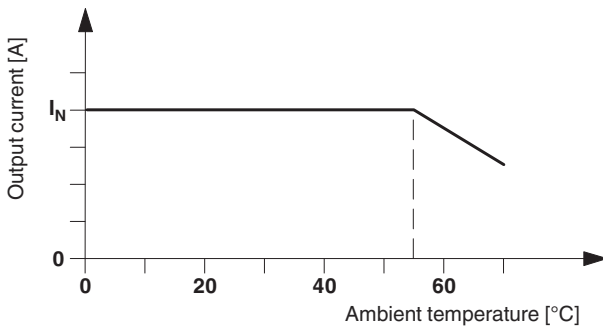

Thermal behavior

With an ambient temperature of up to +55°C, the device supplies the continuous output current of I_N . In the case of ambient temperatures above +55°C, the output current must be reduced by 2.5% per Kelvin increase in temperature. The device does not switch off at ambient temperatures of +70°C or thermal overload. The output capacity is reduced as far as necessary to provide device protection. After it has cooled down, the output capacity is increased again.

Parallel operation

Devices of the same type can be connected in parallel to enable both redundancy and an increase in efficiency. No other alignment is necessary when in the state of delivery.

If the output voltage is adjusted, a uniform distribution of power is guaranteed by setting all parallel operated power supply units to exactly the same output voltage.

To ensure symmetrical distribution of power, we recommend designing all cable connections from the power supply unit to a busbar of the same length and with the same conductor cross section. The system makes it advisable to install a protective circuit at the output of each device when more than two power supply units are connected in parallel (e.g. decoupling diode or DC fuse). This prevents high reverse feed currents in the event of a secondary device fault.

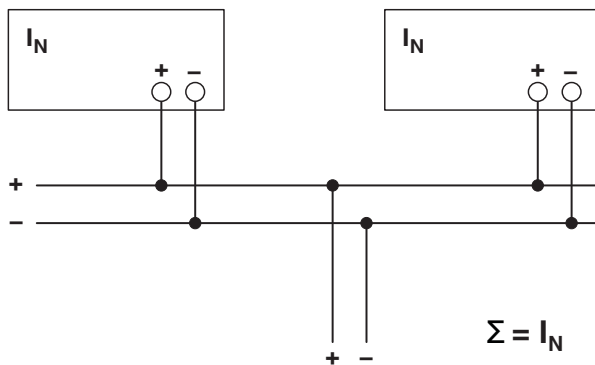

Redundant operation

Redundant circuits are suitable for the supply of systems which make especially high requirements on the operational safety. If a fault occurs in the primary circuit of the first power supply unit, the second device automatically takes over the entire power supply, without interruption, and vice versa. For this reason, the power supply units to be connected in parallel are dimensioned in such a way that the total current requirement of all consumers can be completely covered by one power supply unit. 100% redundancy makes external decoupling diodes necessary (QUINT-DIODE/40, Order No. 2938963)!

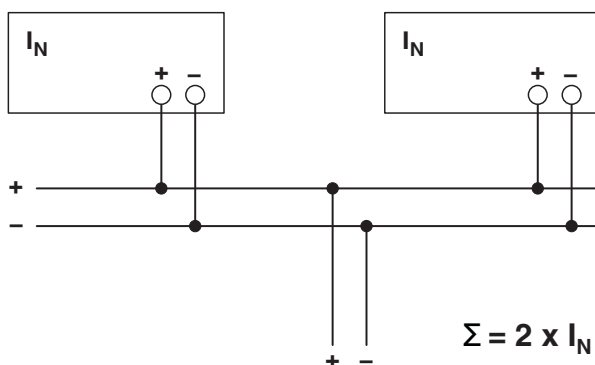

Increased performance

For n parallel connected devices, the output current can be increased to $n \times I_N$. Parallel connection to increase efficiency is used for the expansion of existing systems. It is advisable to use parallel connection if the power supply unit does not cover the current requirement of the most powerful consumer. Otherwise the consumers should be spread among individual devices independent of one another. A maximum of five devices can be connected in parallel!